

PAPER • OPEN ACCESS

Monitoring and Optimizing Solar Power Generation of Flat-Fixed and Auto-Tracking Solar Panels with IoT System

To cite this article: Ku Azmie Ku Husin *et al* 2021 *IOP Conf. Ser.: Mater. Sci. Eng.* **1062** 012011

View the [article online](#) for updates and enhancements.

You may also like

- [Technology analysis for internet of things using big data learning](#)
K Senthilkumar, Vijayan Ellappan and Ajay
- [A Study for taking an approach in Industrial IoT based Solution](#)
Kazi Hassan Shakib and Farhin Faiza Neha
- [Robotic Arm With Real Time Human Arm Motion Replication Using IoT](#)
Kodidety Solomon Jones and R. Uday Kumar



The Electrochemical Society
Advancing solid state & electrochemical science & technology

241st ECS Meeting

May 29 – June 2, 2022 Vancouver • BC • Canada

Extended abstract submission deadline: Dec 17, 2021

Connect. Engage. Champion. Empower. Accelerate.
Move science forward



Submit your abstract



Monitoring and Optimizing Solar Power Generation of Flat-Fixed and Auto-Tracking Solar Panels with IoT System

Ku Azmie Ku Husin¹, Norfatihah Mohd Adenam¹, Muhamad Yuzaini Azrai Mat Yunin¹, Khairul Nizar Syazwan Wan Salihin Wong², Siti Zaiton Mohd Hashim² and Hasyiya Karimah Adli^{2*}

¹Faculty of Bioengineering and Technology, Universiti Malaysia Kelantan, 17600, Jeli, Kelantan, Malaysia.

²Institute for Artificial Intelligence and Big Data, Universiti Malaysia Kelantan, City Campus, Pengkalan Chepa, 16100 Kota Bharu Kelantan, Malaysia.

*Corresponding e-mail: hasyiya@umk.edu.my

Abstract. In this work, the integration of recent digital technology of Internet of Things (IoT) with solar energy management was made to monitor real-time data of panel voltage (V_{pv}) and current (I_{pv}) of the solar panel. The solar panels were installed in Kelantan, Malaysia and this integrated solar power plant with IoT was developed with hardware setup and virtually tested to enhance the tracking behaviour of the proposed system. The comparison of different tilt angle of solar PV shows that solar PV facing the sun perpendicularly (45°) generated higher power generation compared to flat-fixed (0°). Whilst, by comparing fixed angle (45°) and auto tracking solar panel, the power generation recorded can reach up to double performance value (230 W) compared to 170 W generated from 45° fixed angle of solar PV. The IoT-based control of solar power significantly improves the performance of monitoring and maintenance of the power plant parameters with ease monitoring, cost-effectiveness and 24/7 remotely controlled.

Keywords: photovoltaic panel, tilt angles, solar tracker, Internet of Things (IoT)

1. Introduction

Renewable energy promotes significant advantages and benefits compared with conventional energy sources, considering its clean and abundant energy resources [1]. The renewable energies usage is projected to grow massively in coming decades in order to reduce the energy dependence on coal, fuel, oil and other non-renewable energy resources [2-6]. The rising energy demands in every year, uncontrollable environmental pollution and rapid decline of fossil fuels resource have made renewable energy sources, i.e., wind, solar, geothermal, biomass, and tidal energy as better energy options [7-9].

The renewable energy sources in Malaysia have immense potential to generate electricity and these resources play a vital role in resolving the energy crisis. Among the energy resources, solar energy has received greater attention due to its abundantly available, free, inexhaustible and carbon-free energy resources. Solar energy can supply electricity power on a wide scale to satisfy the load requirements, even for rural area use that has limited access to electricity [10-12].

To date, IoT is gaining a prominent position in research worldwide especially in advanced wireless communication and becomes as the foundation for various development applications such as for smart health services [13], smart living [14], smart school education [15] and other sectors [16,17]. IoT uses a wireless sensor network (WSN) for gathering information to monitor and remote-control [18,19]. The hardware consists of end devices fitted with a range of sensors to track various parameters such as temperature, humidity, solar radiation, soil moisture which can be able to communicate the obtained data to other devices [20-25].



Thus, in this work, solar panel is used as primary generation resource with the battery as energy storage system, coupled with AC bus through appropriate converters [20] and DC load is supplied by rectification to AC / DC. Moreover, the Internet of Things (IoT) system is also used to integrate the system, in which this work consists of three objectives:

- a) To identify the daily trend and maximum solar power generation in Kelantan, Malaysia.
- b) To optimize the maximum power generated from different tilt angle of 45° and 0° .
- c) To monitor the solar performance using IoT system by comparing fixed angle (45°) and auto tracking solar panel.

2. Experimental Setup

In this work, 50 W solar photovoltaic (PV) array, charge controller, motors, 12V DC solar battery, DC load, base of PV Array auto moveable, light sensors, inverter and IoT sensors hardware and software were used.

2.1. Solar System Set-up Analysis

This work was conducted from May 2019 until September 2019 at Kampung Pulau Melaka, Kota Bharu, Kelantan, Malaysia. The design of the solar system with IoT-equipped technology was carried out to power water pump for fertigation, as illustrated in Figure 1.



Figure 1. The concept of solar system with IoT-based technology to power water pump for the fertigation

2.2. Hardware Design

The design of the hardware consists of 2 parts, namely mechanical and the control circuit design. The control circuit was equipped with a drive motor, to move the mechanical hardware.

The first step in creating a solar tracker is mechanical design, which the mechanical solar tracker plays a very important role in monitoring the sun. As a part mount and solar tracker frame, PVC pipe was cut and built to support solar panels and has versatile motion feature as required. The built of fixed and auto solar trackers can be seen in Figure 2 as follows:

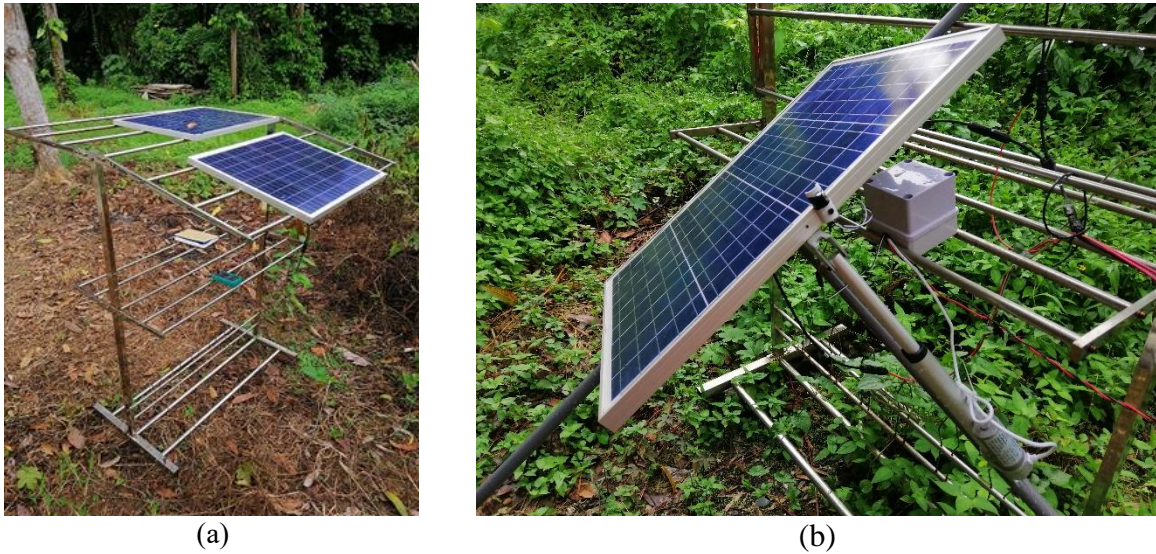

Figure 2. (a) Flat-fixed solar panels (b) auto tracker of solar panels

Two LDR driver circuits were designed to place the LDR in the detection of light and transfer to Linear Actuator by connecting with Arduino UNO. Figure 3 shows a schematic description of the LDR driver circuit.

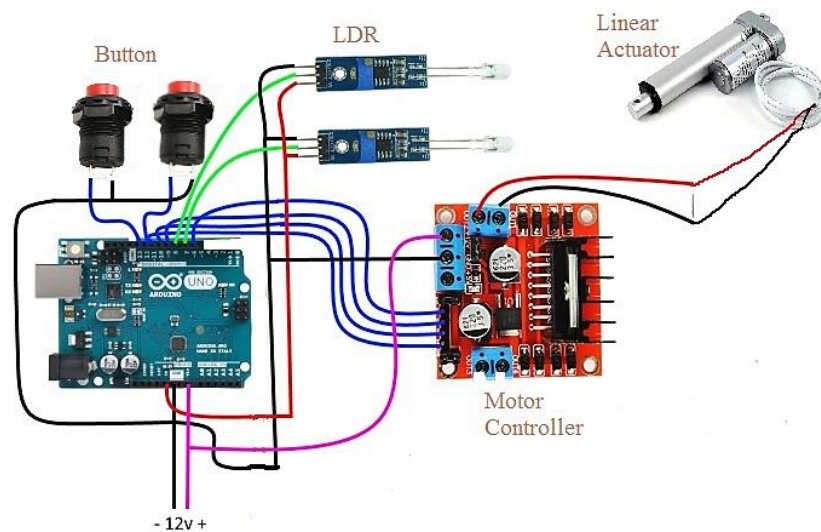

Figure 3. LDR schematic

The linear actuator series was designed as a driving force in light detection, with following specifications:

- Speed: 20mm/s
- Torque: 500N
- Working voltage: 12V DC
- Lever length: 150mm

The electrical architecture consists of sensors as inputs, Arduino UNO kits as signal processors and linear actuators as output.

2.3. Real-time Monitoring with Internet of Things (IoT)

The overall system consists of single axis solar PV system, series of sensors (e.g., current, voltage, temperature), ESP8266 Nodemcu as microcontrollers and Adafruit as platform. The solar PV generates electricity (voltage and current) which were detected by the sensors and data was sent to process by ESP8266 Nodemcu before the user can display and control the data through Adafruit IO platform. IoT was used to connect sensors and actuators and PV power machines to input / output control systems Adafruit application and the Arduino device were connected to Adafruit server via Wi-Fi while Arduino devices use the ESP8266 Wi-Fi module that connected to the local wireless network. Programming Integrated Development Environment (IDE) Arduino UNO to run the Arduino board software was used to write programs in C language that can give commands to the Arduino board and upload programs to a microcontroller. The list of IoT hardware is listed in Table 1.

Table 1. IoT Hardware used in this work

No	Hardware	Number
1	Solar Panel 50 Watt	2
2	30A Charge Controller	1
3	Solar Battery 26 Ah	1
4	Fuse Kit	2
5	INA219 Breakout	2
6	ESP8266 Nodemcu	1
7	Wire of correct gauge for power and distance need to run	As required

3. Result and Discussion

The solar power generated in daily from 0800 hours until 1900 hours was initially investigated in order to identify the solar trend in this region. The data were extracted from the analysis carried out from 26 Jun until 3 July 2019, as shown in Figure 4.

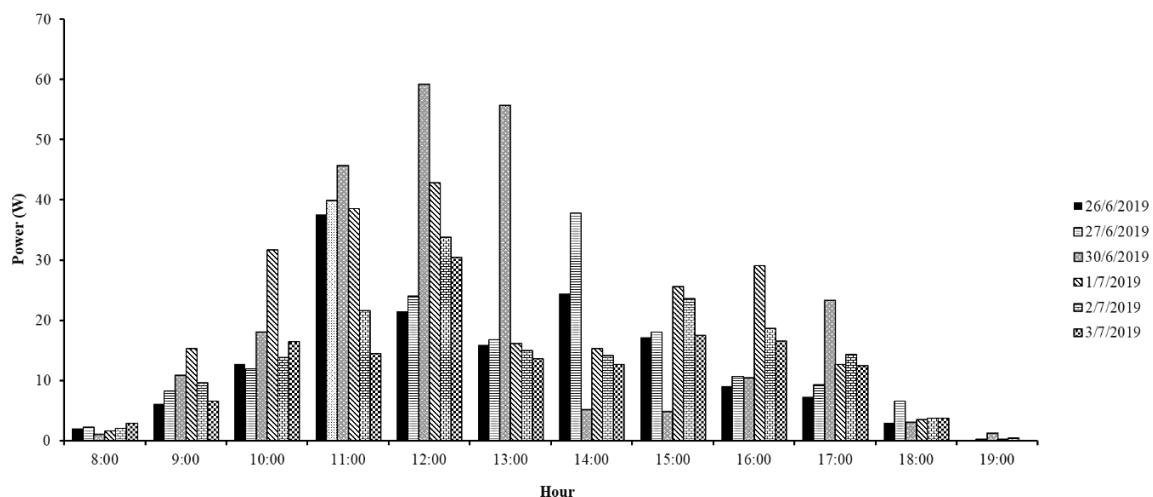

Figure 4. Daily solar power generation from 0800 until 1900

From the results, the highest energy generated was about 60 W recorded at 12 PM showing the maximum sunlight intensity at this hour. On the other hand, the least energy generated at 7 PM only recorded for about 0.14 W, due to sunset. The total solar power generation daily was then recorded everyone hour in order to identify the capacity of solar panel can run the power pump for fertigation. Figure 5 shows the plot of maximum PV watt in daily, exhibited that the total power generated can reach 300 W daily. The value data can be seen varies due to the local weather during analysis was performed.

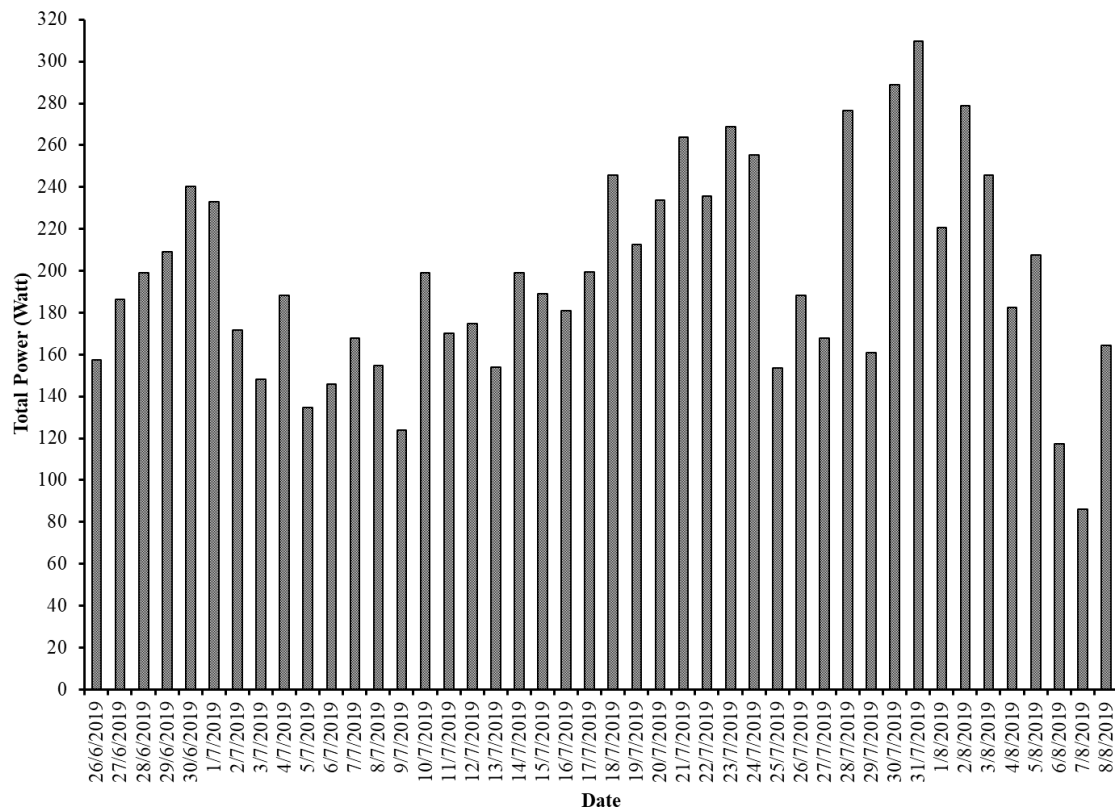

Figure 5. Daily total solar power generated

Meanwhile, the difference of tilt angle analysis of PV panel at 45° and 0° was further evaluated in terms of solar performance. From literature, the rainwater, soil, mud and dust could deposit on the horizontal panel (0°) tilt angle plates which then effect on solar absorption [26]. Figure 6 shows the difference power (W) collected from PV solar panel from manual fitted at 45° and 0° . It can be clearly seen that PV solar panel at 45° generated higher power (W) compared to 0° .

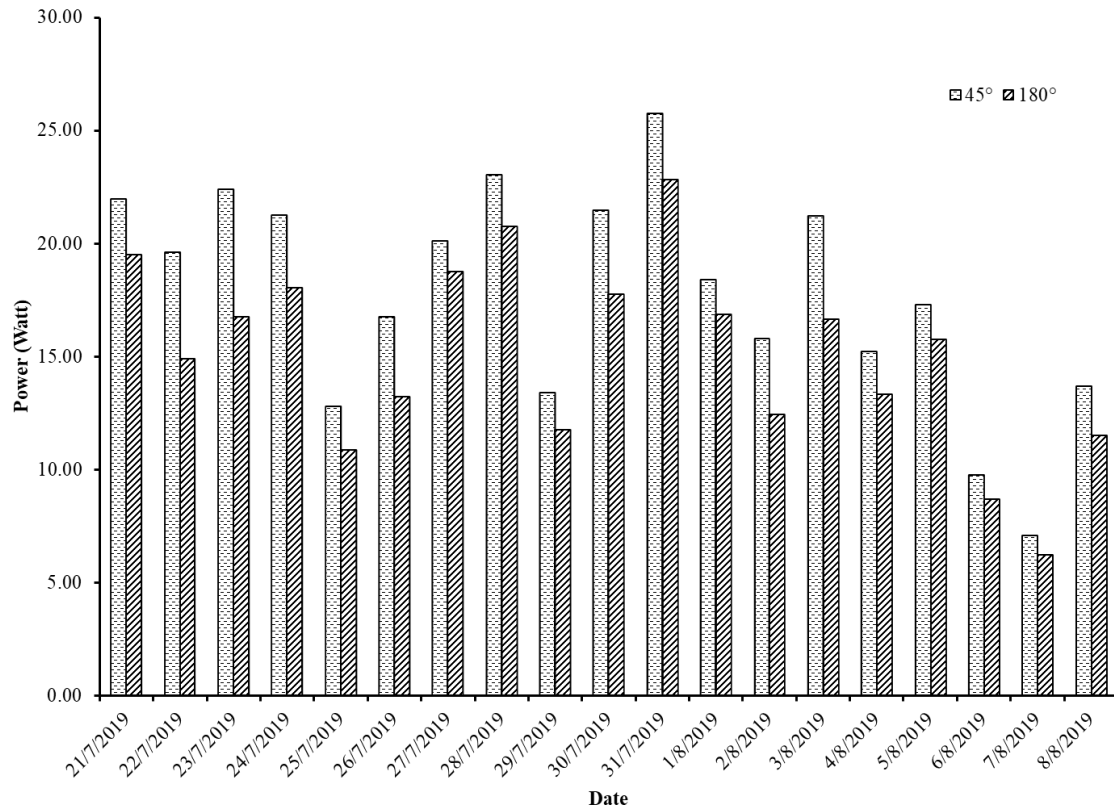

Figure 6. PV solar generation 45° and 180° tilt angles facing the sunlight

As the previous findings showed that better performance of 45° tilt angle solar PV, the analysis continued with the comparison of manual and auto track solar panel. Figure 7 shows the difference of power generation of flat-fixed (45°) and auto track solar panel.

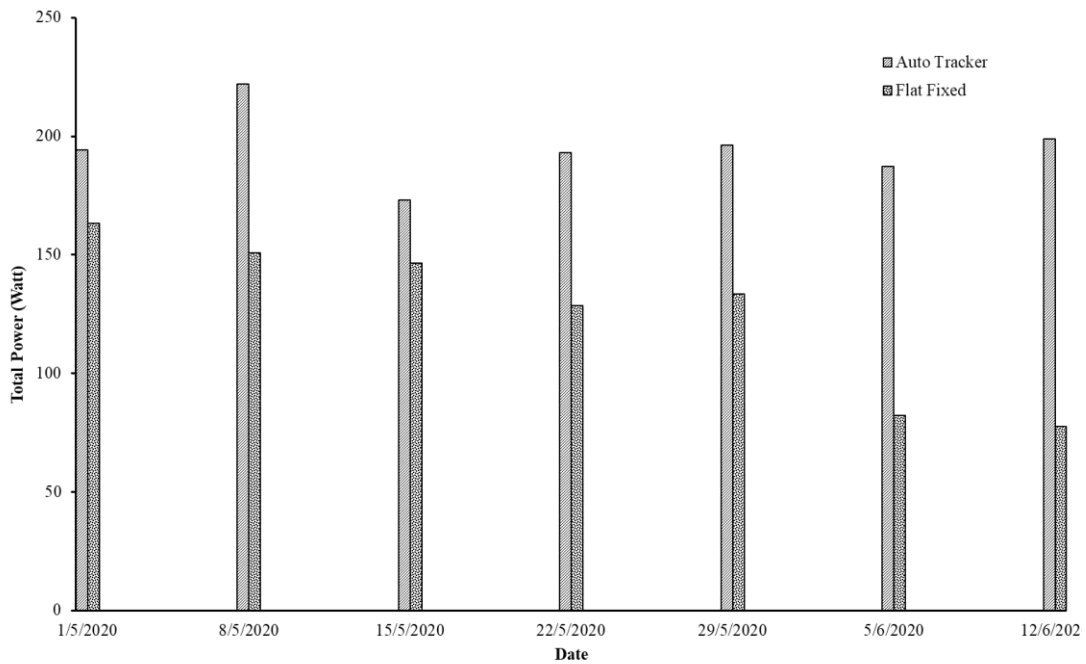

Figure 7. PV solar generation of auto and flat-fixed trackers

From the Figure 7, higher power (W) generation of auto tracker can be explained due to its ability in tracking the sun mode which can maximise more electrical energy can be harvested than flat-fixed position. The sun radiation hits the absorbing surface perpendicularly and it has better conditions of cooling and self-cleaning [26]. The measured values were recorded higher, as the linear actuator rotated the panel perpendicular to the direction of sunlight. Therefore, total solar panel surface areas for solar tracker device for absorbing sunlight are much larger compared to fixed solar panel and produce more performance value.

4. Conclusion

In this study, flat-fixed and auto solar tracker were built with developed IoT system for monitoring the solar generation power generation in Kelantan, Malaysia. The finding shows that solar PV facing the sun perpendicularly (45°) generated maximum power generation compared to flat-fixed (0°). By comparing fixed angle (45°) and auto tracking solar panel, the power generation recorded higher when using auto tracking sunlight. This work highlighted the IoT-based control of solar power significantly improves the performance of monitoring and maintenance of the power with ease monitoring, cost-effectiveness and 24/7 remotely controlled.

References

- [1] Alik R, Jusoh A and Sutikno T 2017 *Int. J. Electr. Comput. Eng.* **7** 29–40
- [2] Boulmrharj S, Malek Y N, Abdellatif E and Bakhouya M 2018 *Energy Procedia* **153** 56–61
- [3] Sreenath S, Sudhakar K, Yusop A F and Solomin E 2020 *Energy Reports* **6** 698–712
- [4] Qin J, Hu E and Li X 2020 *Energy Built Environ* **1** 11–26
- [5] Shaffer B, Flores R J, Samuelson S and Anderson M 2018 *Energy Procedia* **149** 25–38
- [6] Rizman Z I et al 2018 *J. Fund. Appl. Sci.* **10** 689-704
- [7] Chandra S and Gaur P 2020 *Procedia Comput. Sci.* **167** 2354–2363
- [8] Abrishambaf O, Lezama F, Faria P and Vale Z 2019 *Energy Strateg. Rev.* **26** 1-17
- [9] Pavel S O and Nikita V K 2018 *MATEC Web of Conferences* **226** 02023-02026
- [10] Munir E, Sipayung F C, Priyani N and Suryanto D 2018 *Earth Environ. Sci.: IOP Conf. Series* **126** 1-7
- [11] Soeprijanto A 2018 *IOP Conf Series: Mater. Sci. Eng.* **383** 1-7
- [12] López-Vargas A, Fuentes M and Vivar M 2018 *IEEE Sens. J.* **19** 679-691
- [13] Solanas A, Patsakis C, Conti M and Vlachos I 2014 *IEEE Commun. Mag.* **52** 74-81
- [14] Mahesar S, Baloch M H, Kaloi G S, Kumar M, Soomro A M, Solangi A A and Memon Y A 2018 *Int. J. Adv. Comput. Sci. Appl.* **9** 216–219
- [15] Ming T, Hall C, Azman H and Joyes G 2010 *Int. J. Educ. Dev. using ICT* **6** 5-20
- [16] Adhya S, Saha D K, Das A, Jana J and Saha H 2016 *2nd. Int. Conf. Control, Instrumentation, Energy, Commun.* **2016** (Kolkata: India) pp 432–436
- [17] Kandimalla J 2017 *Int. J. Mod. Trends Sci. Technol.* **04** 16–21
- [18] Visconti P 2020 *Int. J. Electron Telecommun.* **66** 59–68
- [19] Sabry A H, Hasan W Z W, Kadir M Z A A, Radzi M A M and Safie S 2017 *PLoS One* **12** 1–22
- [20] Kyi S and Taparugssanagorn A 2019 *Digit Commun. Networks* **6** 51–57
- [21] Witkowski K 2017 *Procedia Eng.* **182** 763–9
- [22] Sunhare P 2020 *J. King Saud Univ. – Comput. Inf. Sci.* **2020** 1-22
- [23] Ray P P 2016 *Futur. Comput. Informatics J.* **1** 35–46
- [24] Reyna A, Martin C, Chen J, Soler E and Diaz M 2018 *Futur. Gener. Comput. Syst.* **88** 173–190
- [25] Maghami M R, Hizam H, Gomes C, Radzi M A, Rezadad M I and Hajighorbani S 2016 *Renew. Sust. Energ. Rev.* **59** 1307-1316
- [26] Ziemelis I 2017 *Eng. Rural Dev.* **16** 540–545